



ML200-12.8 UT

Ultra Thin LFP Lithium Battery

- 1- Temperature requirements for battery operation: Charge and discharge temp: $-20^{\circ}\text{C}\sim 60^{\circ}\text{C}$.
- 2- Humidity requirements for the external environment of the battery : $10\%\leq\text{Humidity}\leq 90\%\text{RH}$.
- 3- Please maintain more than 20% SOC when the battery is under operation.
- 4- When the battery is not being used for a short period of time, please maintain more than 60% SOC and store it in a dry, clean and well-ventilated warehouse at the temperature between 5°C to 45°C .
- 5- When packaging the battery, please move it gently to prevent it from being thrown, rolled or hit.
- 6- Do not put it upside down in the storage state; it is strictly prohibited to expose the battery pack to long-term exposure, rain or water.
- 7- Ensure that the battery system is kept away from flammable and explosive materials and high temperature environment during operation or storage.
- 8- It is not allowed to operate the battery under short circuit, overcharge high temperature alarm state.



Marvel Tech
Ultra Thin LFP Lithium Battery

ML200-12.8 UT
12.8V 200Ah 2560Wh

Warning: Risk of fire, explosion or burn
1. Do not short circuit the (+) and (-)
2. Do not immerse, throw or wet battery in water
3. Do not heat above 60°C or throw battery into fire
4. Do not disassemble, crush or modify the battery
5. Stop using the battery if abnormal heat, deformation or abnormal condition is detected

S/N

Made in China

INFORMATION	
RATED VOLTAGE	12.8V
MAX CHARGE V	14.6V
CUT OFF V	10V
STOCHARGE CURRENT	40A
MAX CONTINUOUS DISCHARGE CURRENT	200A
PEAK DISCHARGE CURRENT (3S)	300A
OPTIMAL CHARGE TEMPERATURE	$<45^{\circ}\text{C}$

www.marvel-tech.ca

Battery parameters

Model	ML200-12.8 UT	
Rated voltage	12.8V	4S1P
Battery working voltage	10~14.6V	2.5V-3.65V
Rated capacity	200Ah	
Total Energy	2.56 KWh	
internal resistance	≤1 5mΩ	
SOC range	20%-100%	
Charge /discharge capacity efficiency	≥96%	
Max.Charge current (A)	200	
Peak discharge current (A)	500	5S
Max Continuous discharge current (A)	200	
Battery cycle life	More than 6000 cycle at 1C (Room temperature) capacity retention rate : >90%	
Battery weight	About:20.4kg	
Relative ambient humidity	10%-90%	
Waterproof Rate	IP55	
Battery construction	4S1P	
Battery charging/discharging ambient temperature range	-20 °C -60 °C	

Product Structure Drawing

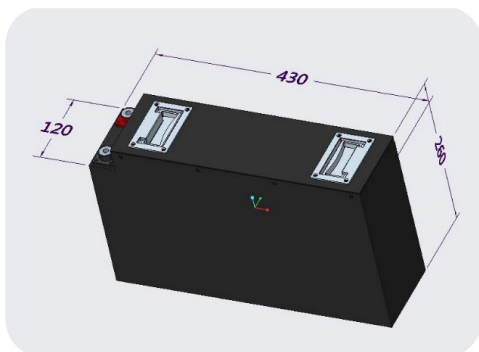

Charge and Discharge Curve

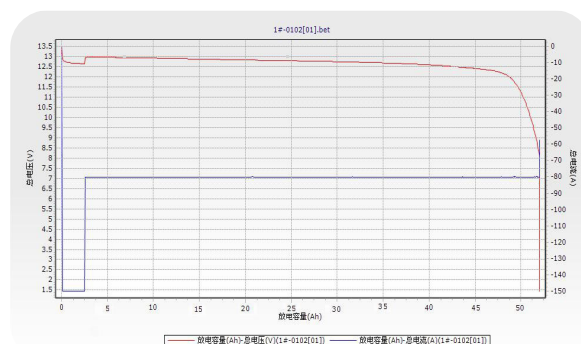

Warnings and Tips

In order to prevent the battery leaking, getting hot and exploding, please pay attention to preventing measure as following:

- Never throw the battery into water, keep it under dry, shady and cool circumstance when not use.
- Never upside down the positive and negative.
- Never connect the positive and negative of battery with metal.
- Never ship or store the battery together with metal.
- Never knock, throw or trample the battery.
- Never cut through the battery with nail or other edge tool.

(Notices!)

- Never use or keep the battery under the high temperature. Otherwise it will cause battery heat, get into fire or lose some function and reduce the life. The proposed temperature for long-term storage is 10-45 °C.
- Never throw the battery into fire or heating machine to avoid fire, explosion and environment pollution; scrap battery should be returned to the supplier and handled by the recycle station.
- Never use the battery under strong static and strong magnetic field, otherwise it will destroy the protecting device.
- If battery leaked, the electrolyte get into eyes, please don't knead, please wash eyes by water and send to hospital. Otherwise it will hurt eyes.
- If battery emit peculiar smell, heating, distortion or appear any unconventionality during using, storage or charging process, please take it out from device or charge and stop using.
- Never cut the battery in socket directly; please use the stated charger when charging.
- Check the voltage of battery and relevant connectors before using the battery. It can't be used until everything turns out to be normal.
- The battery should be stored in half SOC. It needs to be charged once if out of use for as long as half a year.
- Prior to charging, fully check the insulativity, physical condition and ageing status, since breakage and ageing are never allowed; the pack voltage must not be less than 10 V, if not, it's abnormal and that battery needs to be labeled. The user should contact our Customer Service Dept and It can't be charged until repaired by our staff.
- Clean the dirty electrode, if any, with a clean dry cloth, or poor contact or operation failure may occur